

Selection Guide

Applications

Schneider Electric Forta NSR M800A, and M1500A series linear actuators mount directly onto 2-1/2" to 6" VB-8xxx series and VB-9313 series two-way and three-way globe flanged valve bodies. Applications include chilled or hot water and steam. Field selectable input signals include reverse and direct acting, floating or proportional 0-10 Vdc, 2-10 Vdc or 4-20 mA, and proportional sequencing input signal ranges.

Applicable Literature

- Schneider Electric Forta M400A and M800A and M1500A (F-27599)
- AV-822 Installation Instructions, F-27443
- Schneider Electric Valves catalog, F-27414
- CA-28 Control Valve Sizing, F-13755

Selection Guide Contents

Applications	page 1
Valve and Actuator Selection Procedure	page 1
Schneider Electric VB-8000 Series Valve Bodies. . .	page 2
Schneider Electric VB-9000 Series Valve Bodies. . .	page 3
Valve/Actuator Close-off Pressures	page 4
Schneider Electric NSR Forta Actuator Model Chart	page 4
Ambient Temperature Restrictions	page 4
Close-off Pressure and VB-8xxx Maximum Operating Pressure Differential	page 4
Factory Valve and Actuator Assemblies	page 5
VB-8xxx and VB-9313 Valve Body Action	page 5
NSR Forta Actuator and Valve Body Dimensions . .	page 6
VB-8xxx Dimensions.	page 7
VB-9313 Dimensions	Page 7

Valve and Actuator Selection Procedure

- Determine the required flow coefficient (Cv/kvs).**
Using the required flow and pressure drop for the application, determine the required flow coefficient (consult CA28, F-13755 if necessary).
- Determine valve body part number.**
Select a flanged VB-8xxx valve body from Table-1 or a flanged VB-9313 valve body from Table-2 having the required flow coefficient, size, body pattern, end connection, and temperature/pressure ratings appropriate for the application.

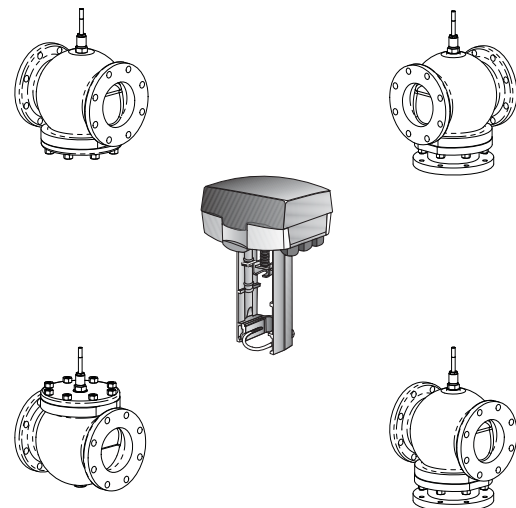

3. Select the Forta Actuator

Using the required close-off pressure for the application, consult Table-5 and select a Forta actuator having sufficient close-off pressure on the valve body selected in step 2. For valve/actuator combinations using VB-8xxx valve bodies, also consult Table-5 for maximum operating pressure differential limitations. Additional Forta actuator specifications may be found in Table-3 or in the Forta Installation Instructions sheets shown in *Applicable Literature*.

If necessary, use the dimensional information in Figure-1, Figure-2, Table-8, and Table-9 to confirm that the valve-actuator assembly will fit in the available space.

4. Determine Assembly Part Number

If a complete factory valve and actuator assembly is required, consult Table-3 for the actuator code of the Forta actuator selected in Step 3. For the complete assembly part number:

- Change the valve body part number prefix from VB to VU.
- Insert the actuator code in the third field of the part number.
- Confirm the factory assembly is available in Table-6

Example:

- Valve body: VB-8213-0-4-14
- Actuator: M1500A (actuator code 686 from Table-3)
- Complete assembly: VU-8213-686-4-14

Forta actuators are field configured for the desired control signal type and range plus the desired action. Consult the appropriate Forta Installation Instructions for further information (see *Applicable Literature*).

Valve Body and Actuator Selection

Table-1 Schneider Electric VB-8213, VB-8223, and VB-8303 Valve Bodies

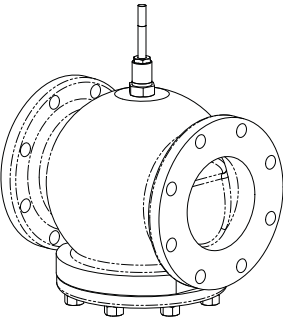
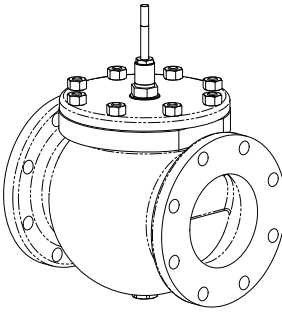
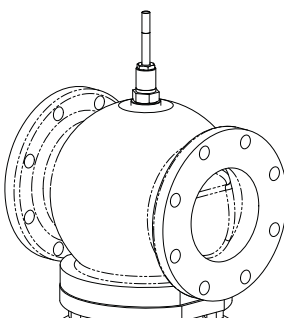
		Application			
		Chilled or Hot Water, Steam		Chilled or Hot Water	
		Two-Way Flanged		Three-Way Flanged	
<p>Two-Way and Three-Way Valves</p> <ul style="list-style-type: none"> • Two-way Stem Up Open or Stem Up Closed • Three-way Mixing/Diverting • ASA 125 Flanged • Cast Iron Body 					
		Size	2-1/2" to 6"	2-1/2" to 6"	2-1/2" to 6"
		Valve Body Part Number	VB-8213-0-5-P	VB-8223-0-5-P	VB-8303-0-5-P
		Valve Body Action	2-Way Stem Open	2-Way Stem Up Closed	3-Way Mixing/Diverting ^a
		Linkage Kit Part Number	AV-822 ^b		
		Material	Flow Type	Equal %	Equal %
Body	Cast Iron		Cast Iron	Cast Iron	
Seat	Forged Brass		Forged Brass	Forged Brass	
Stem	Stainless Steel		Stainless Steel	Stainless Steel	
Plug	Forged Brass		Forged Brass	Forged Brass	
Packing	Spring Loaded TFE/EPDM		Spring Loaded TFE/EPDM	Spring Loaded TFE/EPDM	
Seat Ring	EPDM	EPDM	None		
ANSI Pressure Class, psig		125 (up to 200 psig below 150°F)			
Maximum Inlet Pressure Steam psig (kPa)		35 psig (241 kPa)		—	
Allowable Control Media Temperature, °F (°C)^c		20°F to 281°F (-7°C to 138°C)			
Close-Off Pressure, psi (kPa)		125 psi (856 kPa) ^d		35 psi (241 kPa) ^d	
P Code	Valve Size, In.	C_v (k_{vs})		C_v (k_{vs}) Mixing ^e	C_v (k_{vs}) Diverting ^f
12	2-1/2	56 (48)	56 (48)	80 (69)	95 (82) ^g 115 (99) ^h
13	3	85 (74)	85 (74)	110 (95)	120 (104) ⁱ
14	4	145 (125)	145 (125)	190 (164)	190 (164) ⁱ
15	5	240 (208)	240 (208)	290 (251)	290 (251) ⁱ
16	6	370 (320)	370 (320)	500 (433)	500 (433) ⁱ

^a VB-8303 valves may be used as either mixing or diverting valves. VB-8303 valves will also operate satisfactorily as two-way angle valves if either end (side) port is closed off.

^b AV-822 linkage Kit included when valve/actuator are ordered as a factory assembly. Purchase separately for field assembly.

^c CAUTION: Freeze protection required for temperatures below 32°F (0 °C). Avoid ice formation on stems.

^d Valve in closed position. See Table-5 for maximum allowable VB-8xxx differential pressure for valve in any open position.

^e Mixing configuration, ports A and B are inlets, port AB is outlet. Port AB located on bottom.

^f Diverting configuration, port AB is inlet, ports A and B are outlets. Port AB located on bottom.

^g Diverting configuration, flow AB to A ports.

^h Diverting configuration, flow AB to B ports.

ⁱ All diverting flow configurations, flow AB to either A or B ports.

Table-2 Schneider Electric VB-9313 Valve Bodies

Three-Way Valves

- Three-way mixing
- ANSI 125 Flanged
- Cast Iron Body

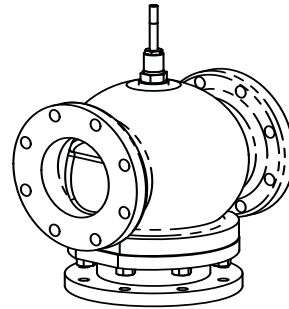

		Application
		Chilled or Hot Water
		ASA Flanged
Size		2-1/2" to 6"
Valve Body Part Number		VB-9313-0-5-P
Linkage Kit Part Number		AV-822
Material	Flow Type	Mixing ^a
	Body	Cast Iron
	Seat	Bronze
	Stem	Stainless Steel
	Plug	Brass
	Packing	Spring Loaded TFE/EPDM
	Disc	None
ANSI Pressure Class, psig		125
Allowable Control Media Temperature, °F (°C)^b		40°F to 300°F (4°C to 149°C)
Allowable Differential Pressure, Water, psi (kPa) ^c		35 psi (241 kPa) Max.
P Code	Valve Size, In.	C_v (k_{vs}) Rating
12	2-1/2	74 (64)
13	3	101 (87)
14	4	170 (147)
15	5	290 (251)
15	6	390 (337)

^a AV-822 linkage Kit included when valve/actuator are ordered as a factory assembly. Purchase separately for field assembly.

^b CAUTION: Freeze protection required for temperatures below 32°F (0 °C). Avoid ice formation on stems.

^c Maximum recommended differential in full open position. Do not exceed recommended differential pressure (pressure drop) or integrity of parts may be affected. Exceeding maximum recommended differential pressure voids product warranty.

Table-3 Schneider Electric NSR Forta Actuator Model Chart

Model	Actuator Code	Force, lbf (N)	Power	Running VA	Transformer Sizing VA	Floating Control ^a	Proportional Control ^a	Feedback	(2) SPDT Auxiliary Switches	Linkage
M800A	680	180 (800)	24 Vac ±10% 50/60 Hz, or 20 to 29 Vdc	15	50 ^c	Yes	0-10 Vdc, 2-10 Vdc, or 4-20 mA _{dc} with 500 ohm resistor	2-10 Vdc	No	AV-822 (purchase separately)
M800A-S2	— ^b			24	50 ^c				24 Vac 4A res.	
M1500A	686	337 (1500)		24	50 ^c				No	
M1500A-S2	— ^b			24 Vac 4A res.						

^a DIP switch selectable.

^b No actuator code. No factory assemblies offered.

^c M800 DC Power 20W, M1500 DC Power 30W.

Table-4 Ambient Temperature Restrictions for Forta Valve Actuators

Fluid Temperature in Valve Body	Maximum Allowable Ambient Temperature ^a
Chilled Water	122°F (50°C)
281°F (138°C)	113°F (45°C)
300°F (149°C)	107°F (42°C)

^a Minimum allowable ambient operating temperature 14°F (-10°C)

Note: When installing valve and actuator assemblies, observe the minimum and maximum fluid and ambient temperature limits shown in Table-1, Table-2, and Table-4.

Table-5 Select Valve/Actuator Combination Having Sufficient Close-off for Application

Valve Body	P Code	Size	Close-off Ratings, psi (kPa)		Maximum Operating Pressure Differential, psi (kPa)
			M800A M800A-S2 ^a	M1500A M1500A-S2 ^a	M1500A M1500A-S2 ^a
VB-8213-0-5-P VB-8223-0-5-P	-12, -13, -14, -15, -16	2-1/2" to 6"	Do Not Use ^b	125 (856)	35 (241) ^c
VB-8303-0-5-P				35 (241)	
VB-9313-0-5-P	-12	2-1/2"	29 (199)	61 (418)	Note: Do not use M400A or M400A-S2 actuators on 2-1/2" to 6" VB-8xxx or VB-9313 valve bodies.
	-13	3"	19 (130)	42 (288)	
	-14	4"	10 (68)	22 (151)	
	-15	5"	—	14 (96)	
	-16	6"	—	9 (62)	

^a AV-821 linkage adapter kit required for mounting (order separately).

^b M800A and M800A-S2 actuators are **not** compatible with VB-8xxx valve bodies.

^c Maximum differential in any open position. For proper VB-8xxx valve operation, do **not** exceed Maximum Operating Pressure Differential.

Factory Assemblies

Table-6 Factory Valve and Actuator Assemblies

VB-8000 Series Valve Assembly Part Number	P Code ^a	Size	Actuator Model (Actuator Code ^b)	VB-9313 Series Valve Assembly Part Number	P Code	Size	Actuator Model (Actuator Code ^b)	
			M1500A (686)				M800A (680)	M1500A (686)
VU-8213-686-5-P VU-8303-686-5-P	12	2-1/2"	X	VU-9313-xxx-5-P	12	2-1/2"	X	X
	13	3"	X		13	3"	X	X
	14	4"	X		14	4"	X	X
	15	5"	X		15	5"	—	X
	16	6"	X		16	6"	—	X

^a Insert P code in last field of assembly part number.

^b Insert actuator code in third field of assembly part number.

Table-7 VB-8xxx and VB-9313 Valve Body Action

Valve Body/ Valve Assembly	Valve Body Description	Stem Up Position	Action (As actuator strokes and valve stem goes down)
VB-8213-0-5-P VU-8213-xxx-5-P	Two-Way Stem up open	Valve open	A to AB flow decreases
VB-8223-0-5-P	Two-way stem up closed	Valve closed	A to AB flow increases
VB-8303-0-5-P VU-8303-xxx-5-P	Three-way mixing	Flow B to AB	B to AB flow decreases A to AB flow increases (common port bottom)
	Three-way diverting	Flow AB to B	AB to B flow decreases AB to A flow increases (common port bottom)
VB-9313-0-5-P VU-9313-xxx-5-P	Three-way mixing	Flow B to AB	B to AB flow decreases A to AB flow increases (common port side)

Dimensions

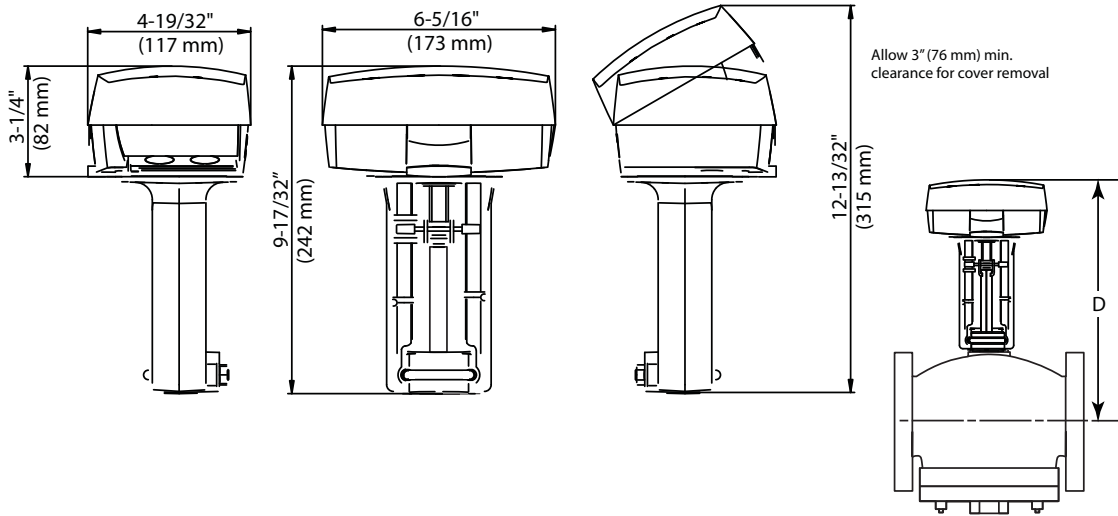
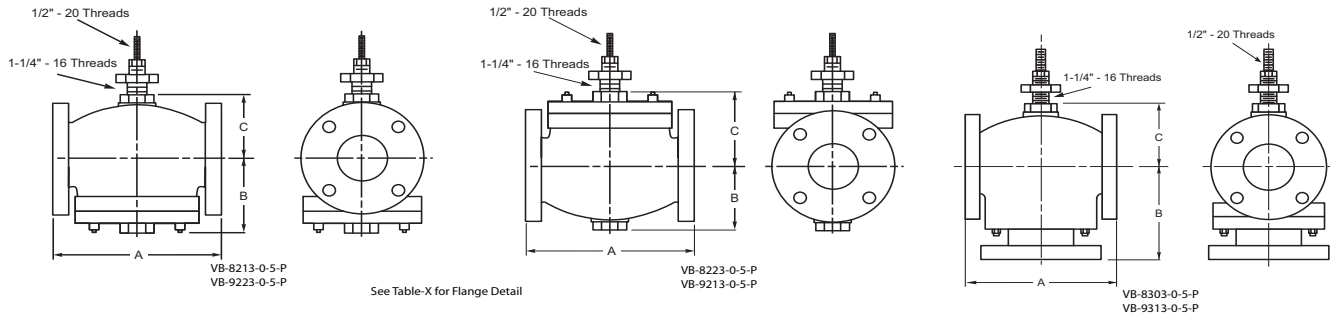
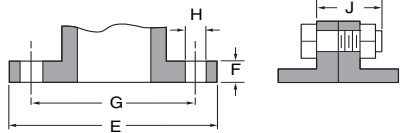

Figure-1 NSR Forta Actuator Dimensions



Flange Dimensions



Nominal Pipe Size	Flanges		Drilling		Bolting		Length of Machine Bolts J
	Flange Diameter E	Flange Thickness F	Diameter of Bolt Circle G	Diameter of Bolt Holes H	Number of Bolts	Diameter of Bolts	
2-1/2	7"	11/16"	5-1/2"	3/4"	4	5/8"	2-1/2"
3	7-1/2"	3/4"	6"				
4	9"	15/16"	7-1/2"	7/8"	8	3/4"	3"
5	10"	15/16"	8-1/2"				
6	11"	1"	9-1/2"				3-1/4"

Figure-2 VB-8xxx and VB-9xxx Valve Body and Flange Dimensions

Table-8 VB-8xxx Dimensions (see Figure-1 and Figure-2)

Valve Body Part Number	Size, Inches	Dimensions in Inches (mm) ^a			
		A	B	C	D ^b
VB-8213-0-5-P	2-1/2	8-9/16 (217)	4 (102)	3-3/8 (86)	13.96 (355)
	3	9-1/2 (241)	4-5/8 (117)	3-3/4 (95)	14.34 (364)
	4	11-1/2 (292)	5-1/2 (140)	4-1/2 (114)	15.09 (383)
	5	13 (330)	6-15/16 (176)	5-13/16 (148)	16.4 (417)
	6	14 (356)	7-1/2 (191)	9-3/16 (233)	19.78 (502)
VB-8223-0-5-P	2-1/2	8-9/16 (217)	4 (102)	3-11/16 (94)	14.59 (371)
	3	9-1/2 (241)	4-1/4 (108)	4-1/16 (103)	14.84 (377)
	4	11-1/2 (292)	4-15/16 (125)	5-5/16 (135)	15.53 (394)
	5	13 (330)	5-7/16 (138)	6-11/16 (170)	16.03 (407)
	6	14 (356)	6-1/4 (159)	10-3/8 (264)	16.84 (428)
VB-8303-0-5-P	2-1/2	8-9/16 (217)	5-7/16 (138)	3-1/16 (78)	16.03 (407)
	3	9-1/2 (241)	6-3/8 (162)	3-11/16 (94)	16.96 (431)
	4	11-1/2 (292)	8-7/16 (214)	4-5/16 (110)	19.03 (483)
	5	13 (330)	8-13/16 (224)	5-5/8 (143)	19.4 (493)
	6	14 (356)	9-3/4 (248)	9 (229)	20.34 (517)

^a See Figure-2 for flange dimensions

^b Assembly height, centerline of valve body to top of actuator (see Figure-1). Leave an additional 3" (76 mm) clearance for cover removal.

Table-9 VB-9313 Dimensions (see Figure-1 and Figure-2)

Valve Body Part Number	Size, Inches	Dimensions in Inches (mm) ^a			
		A	B	C	D ^b
VB-9313-0-5-P	2-1/2	8-9/16 (217)	5-3/8 (137)	3-1/2 (89)	14.09 (358)
	3	9-1/2 (241)	6-3/8 (162)	3-3/4 (95)	14.34 (364)
	4	11-1/2 (292)	8-1/2 (216)	4-1/2 (114)	15.09 (383)
	5	13 (330)	8-3/4 (222)	5 (127)	15.59 (396)
	6	14 (356)	9-3/4 (248)	5-7/8 (149)	16.46 (418)

^a See Figure-2 for flange dimensions.

^b Assembly height, centerline of valve body to top of actuator (see Figure-1). Leave an additional 3" (76 mm) clearance for cover removal.

Copyright 2011, Schneider Electric
All brand names, trademarks and registered
trademarks are the property of their respective
owners. Information contained within this
document is subject to change without notice.

Schneider Electric
1354 Clifford Avenue
P.O. Box 2940
Loves Park, IL 61132-2940
www.schneider-electric.com/buildings

