

# FSLF120-S US Technical Data Sheet

On/Off, Spring Return, 350°F [177°C] for half an hour, 15 s Cycle Time



## Technical Data

Power Supply	120 VAC, ±10%, 50/60 Hz
Power consumption in operation	18 VA
Power consumption in rest position	4 W, 5.5 VA (50 Hz 8 VA), End stop 27 VA, 0.25 A slow blow fuse *
Shaft Diameter	3/8...1/2" round, centers on 1/2"
Electrical Connection	18 GA appliance cable, 3 ft [1 m], with 1/2" conduit connector
Overload Protection	electronic throughout 0...95° rotation
Electrical Protection	grounded enclosure, 120 V
Angle of rotation	95°
Direction of motion motor	selectable by ccw/cw mounting
Torque motor	30 in-lb [3.5 Nm] from 32...350°F [0...177°C]
Direction of motion fail-safe	reversible with cw/ccw mounting
Position indication	Mechanical
Running Time (Motor)	<15 s at rated voltage and torque 32...122°F [0...50°C]
Running time fail-safe	<15 s
Ambient humidity	max. 95% r.H., non-condensing
Ambient temperature	32...122°F [0...50°C]
Storage temperature	-40...176°F [-40...80°C]
Degree of Protection	IP30, NEMA 1
Housing material	galvanized steel
Agency Listing	cULus acc. to UL60730-1A/-2-14, CAN/CSA E60730-1:02, Listed to UL 2043 - suitable for use in air plenums per Section 300.22(C) of the NEC and Section 602 of the IMC. NYC Department of Buildings MEA 197-07-M California State Fire Marshal Listing 3210-1593:102
Noise level, motor	45 dB(A)
Noise level, fail-safe	62 dB(A)
Servicing	maintenance-free
Quality Standard	ISO 9001
Weight	4.4 lb [2.0 kg]
Auxiliary switch	2 x SPST, 3 A resistive (0.5 A inductive) @ AC 250 V, one set at 10°, one set at 85°

† UL File XAPX.E108966

## Fire & Smoke damper actuator

### Application

The type FSLF spring-return actuator is intended for the operation of smoke and combination fire and smoke dampers in ventilation and air-conditioning systems. The actuator will meet requirements of UL555 and UL555S when tested as an assembly with the damper and will meet requirements of UBC for 15 second opening and closing. Square footage of damper operated will depend on make and model and the temperature required.

**IMPORTANT 24VDC NOTE:** The FSLF24 & -S models will not operate below 24VDC. A filtered and regulated power supply must be used.

### Operation

Mounting of the actuator to the damper axle shaft or jackshaft is via a cold-weld clamp. Teeth in the clamp and V-bolt dig into the metal of both solid and hollow shafts maintaining a perfect connection. The specially designed clamp will not crush hollow shafts. The bottom end of the actuator is held by an anti-rotation strap or by a stud provided by the damper manufacturer.

The actuator is mounted in its fail safe position with the damper blade(s) closed. Upon applying power, the actuator drives the damper to the open position. The internal spring is tensioned at the same time. If the power supply is interrupted, the spring moves the damper back to its fail-safe position.

## Dimensions (Inches[mm])

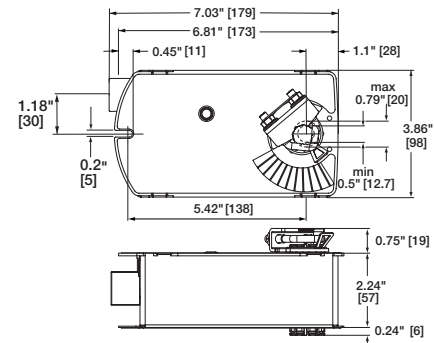

## Safety Notes

\* Neither UL nor Belimo require individual fusing of FSLF actuators. The FSLF draws higher peak current when driving against its end stop or any other type of stop. Given the technology of fuses & breakers, this requires the value of fuse or breaker to be increased to avoid nuisance opening or tripping. A 1 A slow blow should be used for AC 24 V. A 0.25 A slow blow should be used for AC 120 V. A 0.125 A slow blow should be used for 230 V.

### SAFETY NOTES

Wiring and installation must comply with all local electrical and mechanical codes.

The actuator contains no components which the user can replace or repair. Cables are not plenum rated and require flex conduit.

1/2" Threaded Connector: Screw a conduit fitting into the actuator's metal bushing. Jacket the actuator's input wiring with suitable flexible conduit. Properly terminate the conduit in a suitable junction box.

3/8" Flex Connector (-FC models): Mount the flexible conduit into the actuator's metal bushing by means of the provided screw with a torque of 1.2 Nm. Jacket the actuator's input wiring with suitable flexible conduit. Properly terminate the conduit in a suitable junction box.

Accessories	
BAE165 US	165° F electric thermal sensor, SPST, normally closed.
S2A-F US	Auxiliary switch, 2x SPDT, 3A (0.5A inductive) @250 VAC max.

**Typical Specification**

All smoke and combination fire and smoke dampers shall be provided with Belimo FSTF, FSLF, FSNF, or FSAF actuators. All substitutions must be approved before submission of bid. Damper and actuator shall have UL 555S Listing for 250°F (350°F). Actuator shall have been tested to UL 2043 per requirements of IMC 602.2 and NEC 300.22 (c). Where position indication is required -S models with auxiliary switches or damper blade switches will be provided per code requirements.

**Wiring Diagrams**

**APPLICATION NOTES**

- Provide overload protection and disconnect as required.
- Actuators may be powered in parallel. Power consumption must be observed.
- S4 makes to S6 when actuator is powered open.
- Auxiliary switches are for end position indication or interlock control.
- Double insulated.
- Ground present on some models.

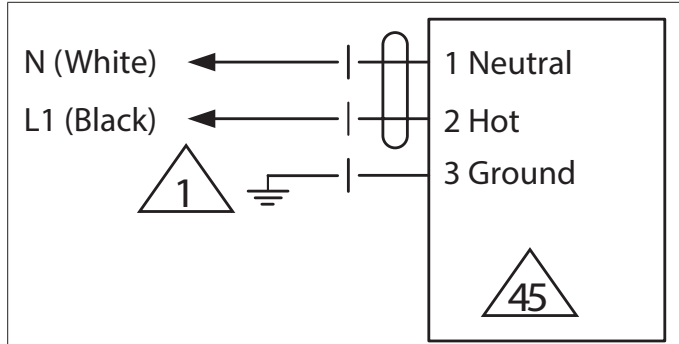

120 VAC

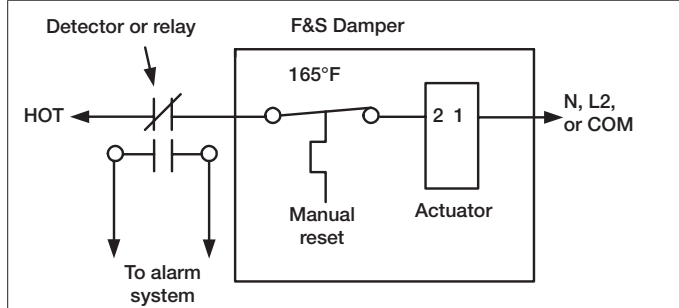

Typical containment damper control wiring

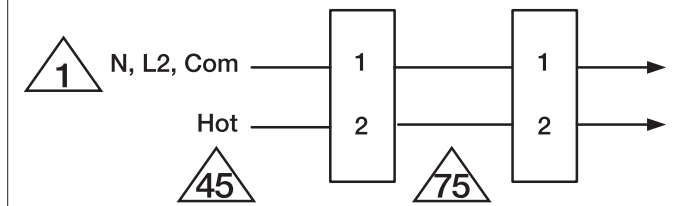

Parallel Actuator Wiring

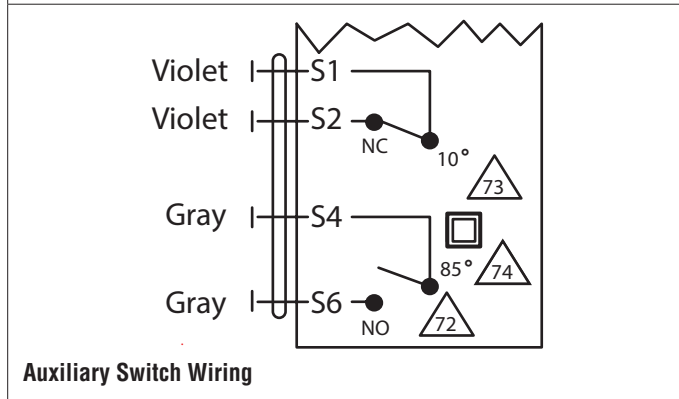

Auxiliary Switch Wiring